

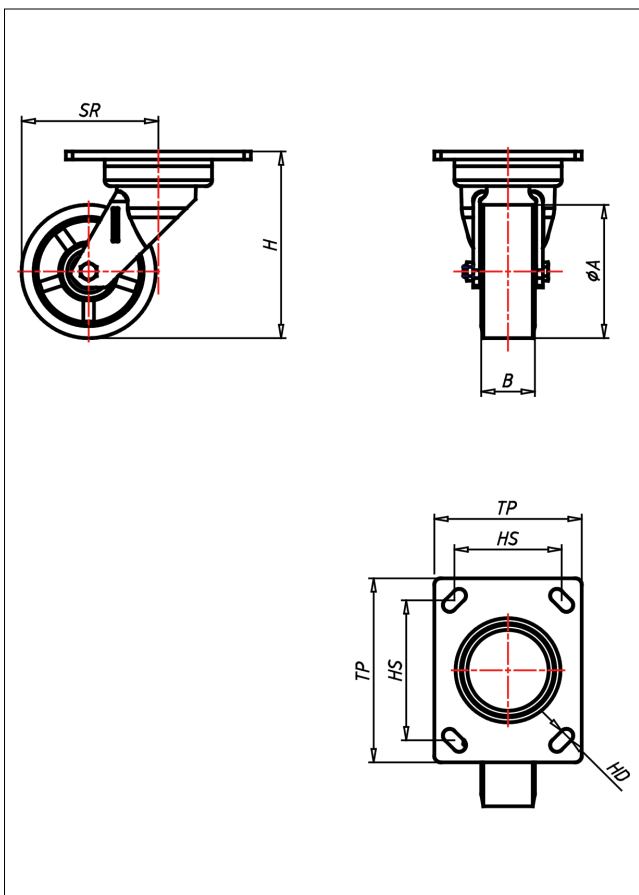

GT-ZK/SUB/LZK

Lenkrolle

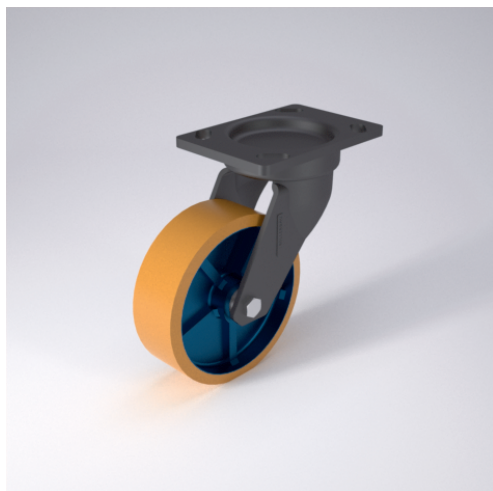

GT-SU



LENKROLLE	RADFESTSTELLER	BOCKROLLE																				
 <ul style="list-style-type: none"> geräuscharmer Lauf geringer Rollwiderstand abrieb- und reifest hohe Stofestigkeit sehr bestndig gegen viele aggressive Medien <p>Guss-Polyurethan Felge Gusseisen lackiert → Seite 247</p> 	 <p>Schwerlastlenkgehuse ohne Mittelbolzen mit gehrtetem Drehkranz und gehrteten Stahlkugeln, geschmiedet und getempert → Seite 42</p>	 <p>AUSWAHLHILFE:</p> <table border="0"> <tr> <td>leicht lenkend</td> <td>-</td> <td>+</td> <td>++</td> </tr> <tr> <td>verschleißarm</td> <td>x</td> <td></td> <td></td> </tr> <tr> <td>stofest</td> <td></td> <td>x</td> <td></td> </tr> <tr> <td>bodenschonend</td> <td></td> <td></td> <td>x</td> </tr> <tr> <td>witterungsbestndig</td> <td>x</td> <td></td> <td></td> </tr> </table>	leicht lenkend	-	+	++	verschleißarm	x			stofest		x		bodenschonend			x	witterungsbestndig	x		
leicht lenkend	-	+	++																			
verschleißarm	x																					
stofest		x																				
bodenschonend			x																			
witterungsbestndig	x																					

Technische Details

ORDERNO (Artikel-nummer)	GT 200 SUB
WDAB (Rad-Ø A x Breite B / mm)	200x51
LC (Tragkraft / kg)	1000
H (Bauhhe H / mm)	250
TP (Plattengre / mm)	150x105
HS (Lochabstand / mm)	105x80
HD (Loch-Ø / mm)	13
SR (Schwenkradius / mm)	185
WB (Radlager)	Rollenlager